

SALONA YACHTS

Matoseva 8
21 210 Solin
Croatia
tel. +385 21 206 855

info@adboats.hr
www.salonayachts.com



PRESS RELEASE

9th of November, 2011

NEW SALONA 35

The new, exciting Salona 35, is going to be presented in January 2012 at Dusseldorf Boat Show.

Every Salona is a result of teamwork of external and internal designers among which we are proud to mention J&J Salona 35 designers, Jason Ker (keel optimization), many Olympic and professional sailors, interior designers, suppliers and most importantly existing cruising or racing Salona customers.

All these people have one simple goal - to design and build globally competitive fast sailing yachts that can win any regatta but at the same time have uncompromised comfort and safety while cruising.

Price starts from 99.500 € (ex. VAT) with special introductory price for first customers.



Exterior

The new Salona 35 is a result of our experience gained throughout creation and daily use of all our models, from 35 to 60 ft.

Her modern and clean deck lines are the continuation of the new distinctive style of Salona that has been introduced by Salona 60 and Salona 38 this summer.

Spacious cockpit is free of obstacles with an easily convertible open to closed transom and an extensive use of carbon details. It has two spacious lockers with additional dedicated locker for two gas bottles, two steering wheels with carbon pedestals (optional) and top quality sailing gear which makes single handed sailing easier.



Interior

Filled with daylight coming through hull windows introduced with Salona 38, with hatches and numerous smart design details, saloon is the perfect place to relax and enjoy the comfort of our new yacht.

Standard interior is 2 cabin version with spacious head and large navigation table, functional galley and folding bunk beds in the saloon (optional).

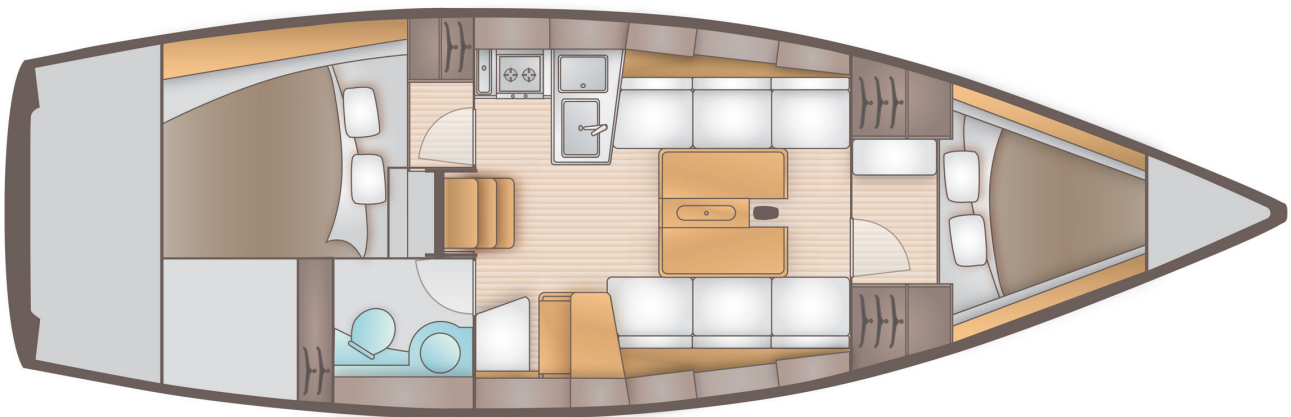

Performance

America's Cup designer, Jason Ker has designed and optimized Salona 35 performance keel with lower center of gravity. Significantly improved ballast to weigh ratio and hydrodynamics of the keel with the use of the latest computational fluid dynamics (CFD) program developed this keel and sail plan optimization for maximum performance combined with ease of handling.

S35 keel is made by most advanced manufacturing and lamination technology and by use of high tech materials.

An optimization of the Salona 35 was carried out focusing on keel, sail plan and flotation with new fin keel or similar design as raced in the World Championships in 2011.

The Salona 35 optimisation was computed using Numeca Fine-Marine RANS CFD on the Ker Yacht Design computing cluster.

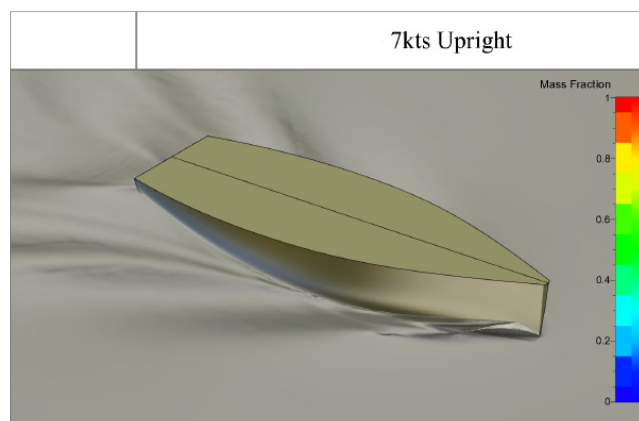
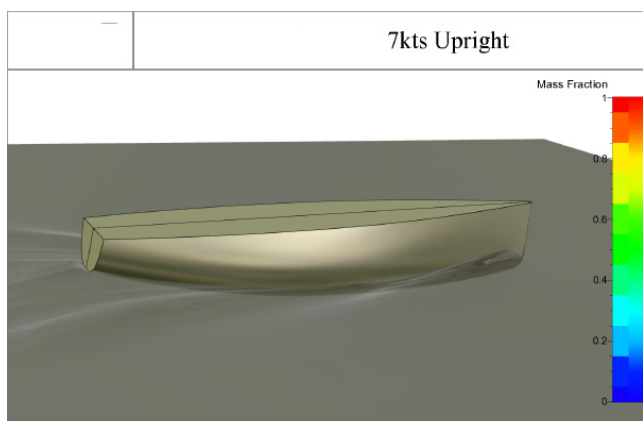
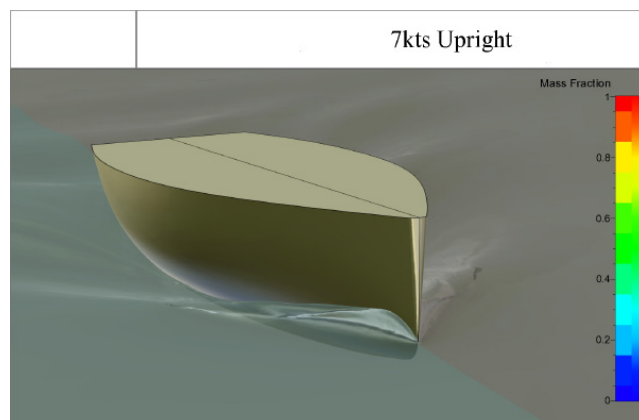
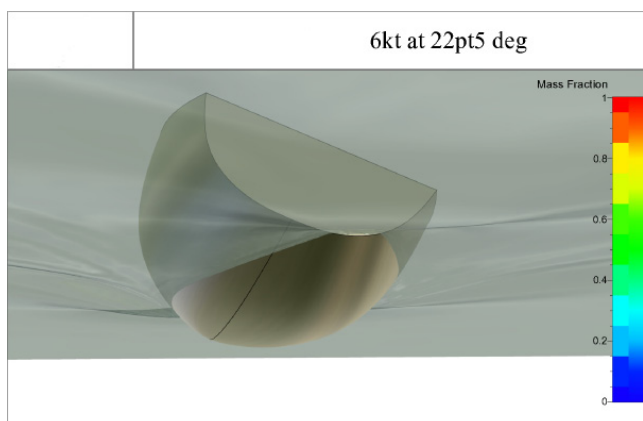
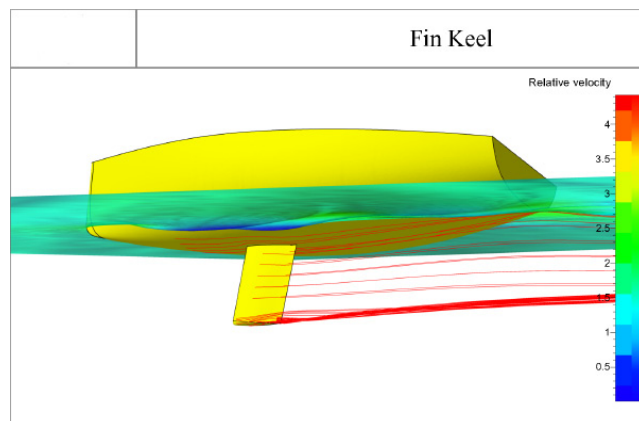
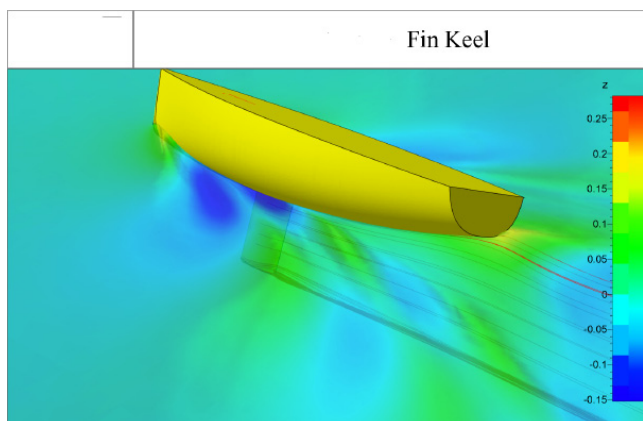
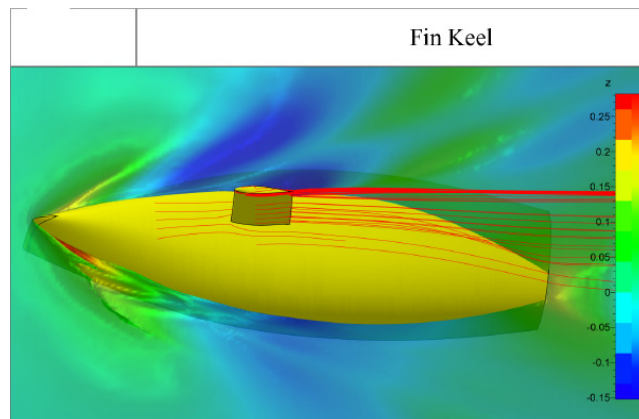
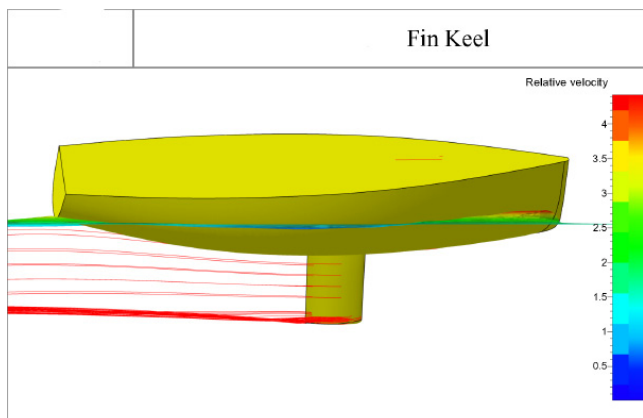

Construction

Construction, technology and innovation have always been the strong points of the Salona yard and on S35 we have combined our experience with the use of hi tech materials and smart design features.

As on all our models the big stainless steel frame takes the loads from the keel and shrouds and spreads them securely to a wide area of the hull.

On the new Salona 35 we have gone one step further in achieving maximum stiffness and durability of the boat by adding the layers of carbon fibre on carefully analyzed areas of hull inner liner to obtain equilibrium of stain-less steel structure and inner liner attached to it.

The slamming zone of the boat has been built a single skin composite in order to avoid shear failure of core material under the heavy loads. That area is additionally reinforced with layers of triaxial E-glass fabric. The use of transparent gel coat and vinilester epoxy resin during the vacuum infusion of the hull is another step towards the superior hull strength and durability.

The deck is sandwich built with a structural design incorporating a ceiling innerliner to better withstand high longitudinal and transverse loads.

Aft and bow bulkheads are completely watertight, thus preventing the possibility of water intrusion in case the exposed parts of the boat (bow and stern) are damaged. Due to strong sandwich construction these bulkheads add extra strength and safety, preserving the weight at the same time.

The final result is a stiff, strong and light construction, optimised for comfortable cruising as well as high performance sailing .

In Salona we believe that Salona 35 is one of the best value 35ft performance cruisers on the market.

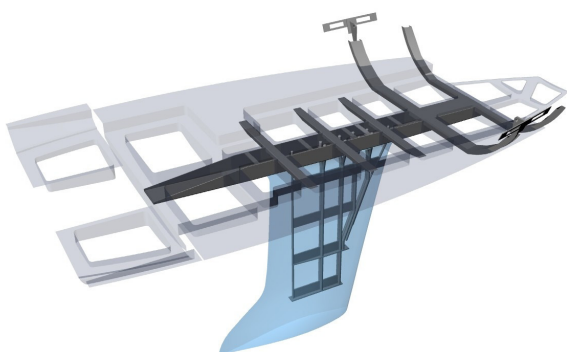

Sail plan

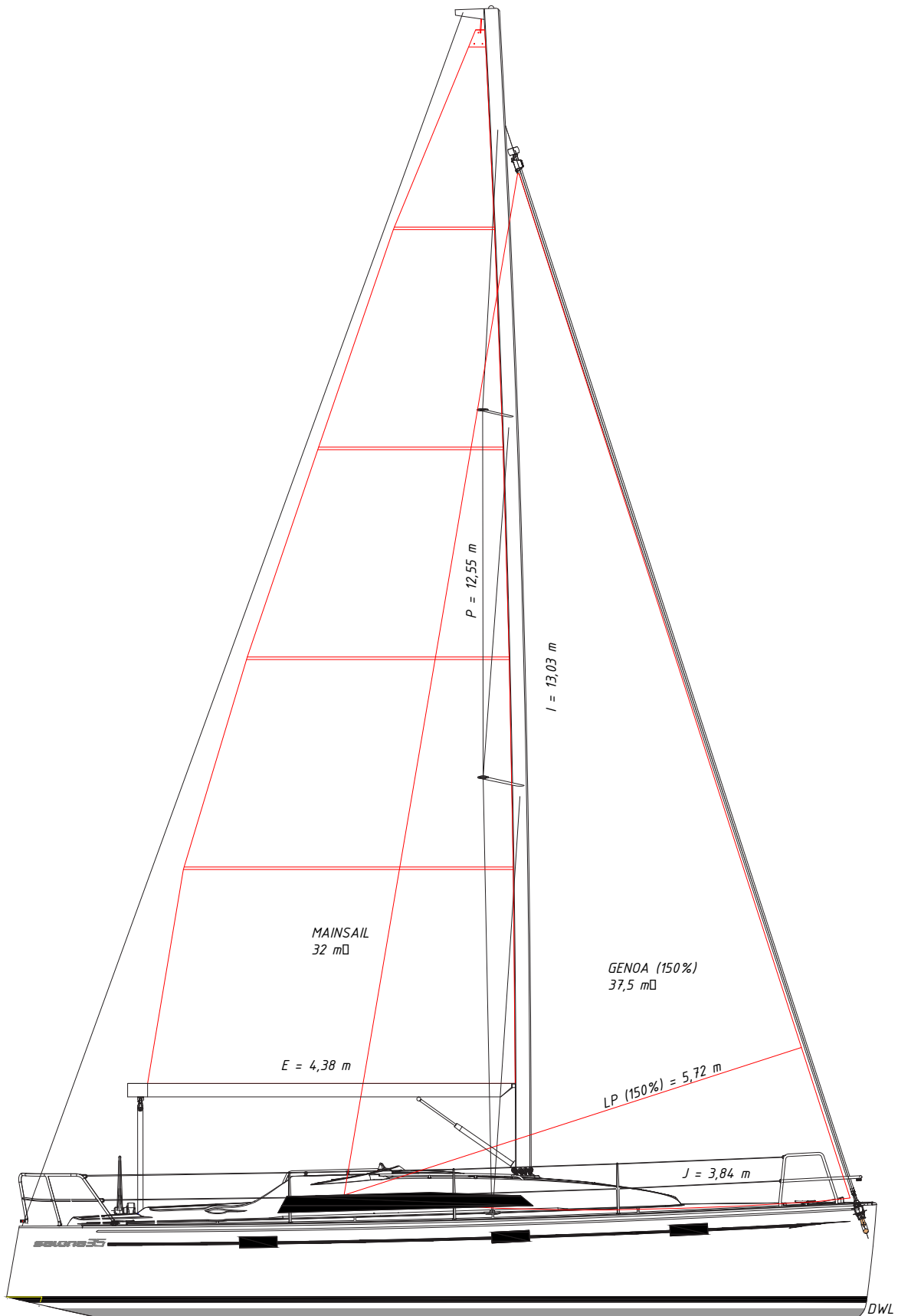

Polar graph

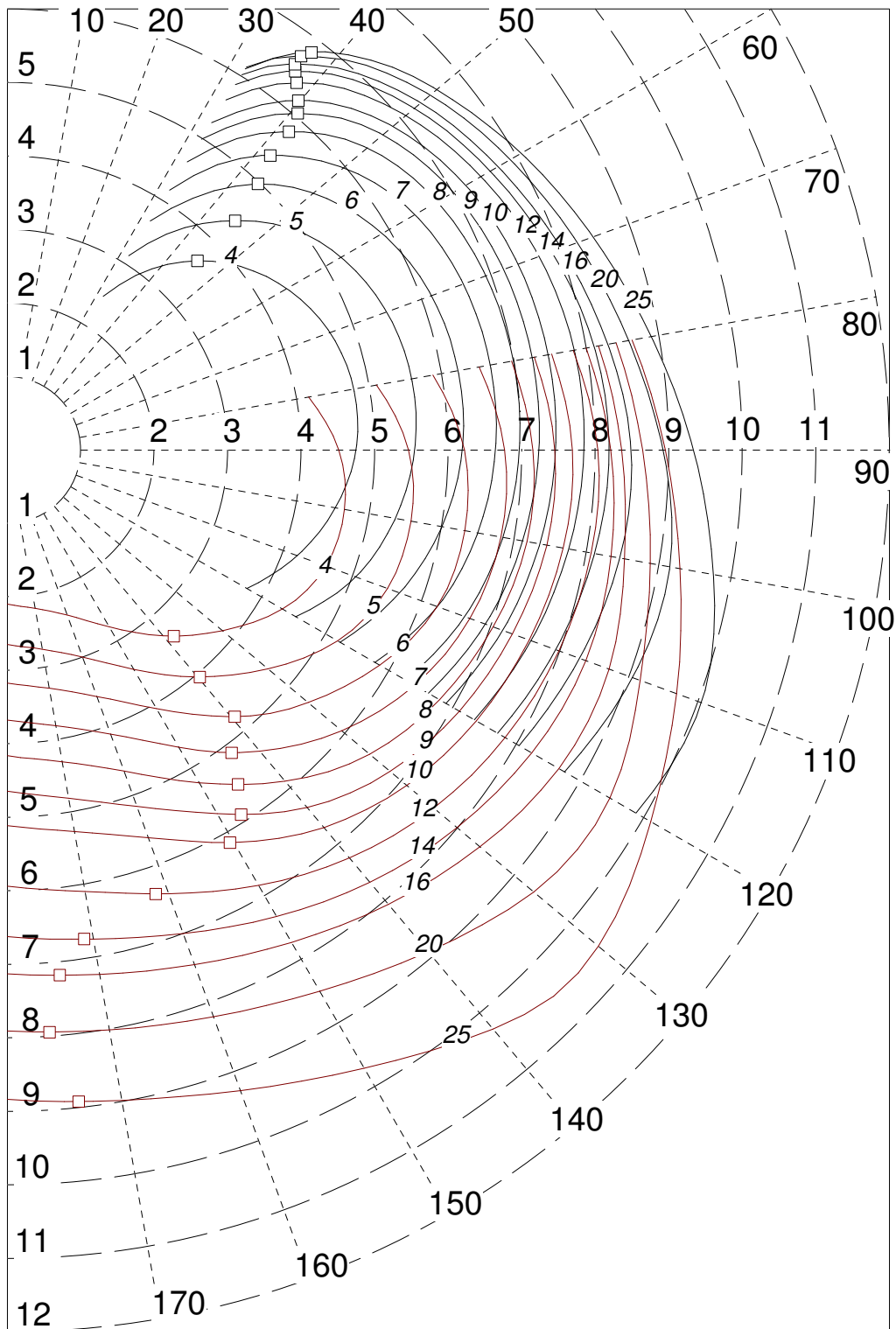

Technical specification

LOA (hull)	10,40 m
LWL	9,16 m
B. max. (deck)	3,36 m
Draft	1,5 / 1,75 / 2,15 m
Balast	1200-1500 kg
DSPL empty	4900 kg
I	13,03 m
J	3,84 m
P	12,50 m
E	4,38 m
Mainsail full batten	32,00 m ²
Genoa furling	37,50 m ²
Sail area total	69,50 m ²
GT	5,30
Fresh water tank	200 l
Black water tank	42 l
Fuel tank	90 l
Engine	15,3 kW (21 HP)
Design Category	A (Ocean)
CE Certification	GL

