

*quality performance comfort*

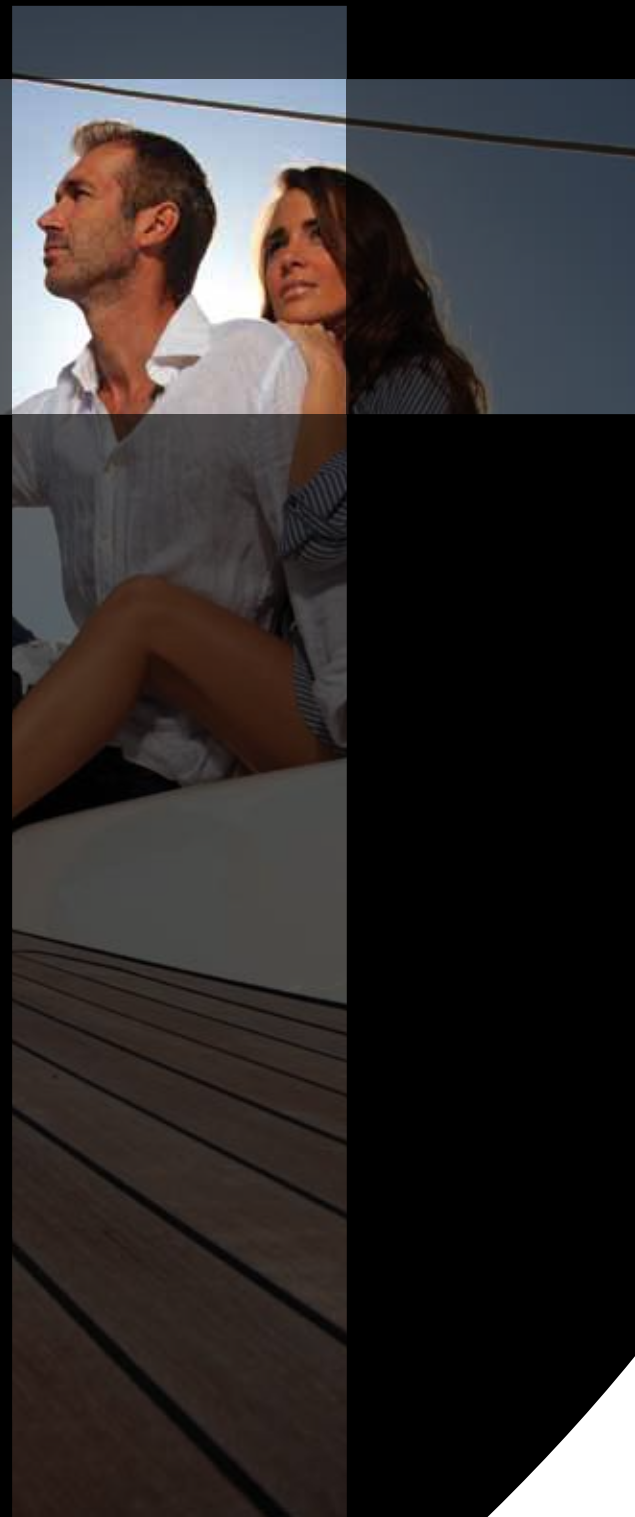

*10 years of excellence*

Welcome to **SALONA YACHTS**

**Dear Sailing Friends – welcome to the Salona family**

We are happy that we can share with you our passion and devotion for building performance sailing yachts. Over time, our experience and understanding of our customers' requirements has grown, leading our workforce to improved production technology and continued development in both the look and functionality of our boats. We have aimed for the top in quality, design and winning performance.

This catalogue explains our philosophy of boatbuilding, however, the best way of understanding Salona is to try our boats where they belong – on the water – and

we welcome the opportunity of arranging this for you. In the next pages we take you through our range, each model is individual, each is aimed for a specific market and, more importantly, each is built with individual attention to its new owner.

Since 2008 Salona Yachts are important part of growing nautical business of Prevent Group of companies. Prevent is German multinational company with over 12000 employees, more than 35 production facilities worldwide and major global supplier to car industry with customers like Porsche, Audi, Volkswagen etc.

**At Salona we go for the best, and we go there for you.**

*Sincerely, Your Salona Team*

**Salona the story of success**

TEN YEARS AGO, Salona began crafting sailing yachts without compromising quality, comfort, or performance. In the years since, we have developed 8 new models winning numerous international accolades. By designing a combination of comfortable cruising amenities in a dynamic, powerful hull we have brought satisfaction to our global customer base on four continents (Europe, USA, Asia and Australia). Our commitment to tireless improvement has resulted in strong CORPORATE GROWTH exceeding 110% during the recent economic crisis and we are excited to celebrate our 10 Year Anniversary by launching our NEW FLAGSHIP, the SALONA 60.

*S35 NEW*

*S38*

*S41*

*S44*

*S60 NEW*

*ibc*



*it makes a difference!*

## QUALITY PERFORMANCE COMFORT



### Quality

We are proud of our uncompromising approach towards quality and product safety. From the very beginning, our yard was dedicated to getting every detail right, aiming for perfection. We have evolved over the years, for example, switching from high quality hand-laid GRP production of hulls and decks towards fully implemented vacuum assisted infusion in combination with advanced resins and glass structure. This we combine with a stainless steel frame which supports the keel, mast and shrouds, giving our boats an extremely strong but light displacement construction – and at Salona we lead the way in this technology.

However, we apply the principle that if something works, don't change it and so we buy the best quality sailing gear, because those are brands you trust and we know will give you reliable and high quality sailing.

### Performance

For every lover of sailing, performance is the key. Whether cruising or racing, good performance makes a difference. It is no coincidence, therefore, that one of the most recognized characteristics of Salona yachts is their amazing performance.

We have focused on overall performance with standard equipment making Salona yachts fun to sail. If you want to switch from family use to racing mode, you purely and simply make changes to the sail inventory.

Our boats have been winning regattas all around Europe whether in the balmy Italian lakes or the enormous North Sea swells for a number of years. Our list of wins is quite impressive, even if we say so ourselves. Whether in club regattas or in serious, unforgiving, all out race meetings, winning is always the best feeling! You can have this feeling with our standard performance cruisers.



*high performance cruising*

*S35 NEW*

*S38*

*S41*

*S44*

*S60 NEW*

*IBC*



**salona**  
performance cruiser

*10 years of excellence*



*high tech boat building...*

And yet there is more – for the dedicated racer we have developed the Salona IBC range which takes you to the next level and the next prestigious win!

**Comfort**

We sail for pleasure. We take the rough with the smooth but whatever we have to face we want to do so in safety and comfort. We have carefully designed our boats for use as family cruisers with young children in mind as well as for serious offshore or international racing with winning in mind.

The Salona is a product of its Mediterranean origins and the outdoors lifestyle that it encompasses. Our boats enjoy airy living spaces internally

and sumptuous accommodation in the cabins, saloon and heads whilst externally the cockpit and generous sunbathing areas make on-board living a joy. Such luxuries are not enough, however, so our boats are designed for heavy weather sailing – with exterior protected areas to keep the storms at bay and you on board as practicably as possible. Down below you have solid grab rails, ergonomically designed galleys to allow easy access to cooking facilities, whatever the weather, open spacious accommodation to allow for a quick change of clothing and somewhere to store wets and keep you dry.

A functional, warm and spacious environment for your family and crew - **Salona, a winning combination.**



*uncompromised construction*

*S35NEW*

*S38*

*S41*

*S44*

*S60NEW*

*IBC*



*10 years of excellence*

# Salona 35

## Perfect COMBINATION

The new, exciting Salona 35 is a result of our experience gained throughout creation and daily use of all our models, from 35 to 60 ft. Her modern and clean deck lines are the continuation of the new distinctive style of Salona that has been introduced by Salona 60 and Salona 38.

Spacious cockpit is free of obstacles with an easily convertible open to closed transom and an extensive use of carbon details. It has two spacious lockers with additional dedicated locker for two gas bottles,

two steering wheels with carbon pedestals (optional) and top quality sailing gear which makes single handed sailing easier.

Construction, technology and innovation have always been the strong points of the Salona yard and on S35 we have combined our experience with the use of hi tech materials and smart design features.

As on all our models the big stainless steel frame takes the loads from the keel and shrouds and spreads them securely to a wide area of the hull. On the new Salona 35 we have gone one step further in achieving

entering salona world



S35 NEW

S38

S41

S44

S60 NEW

ibc

**salona**  
performance cruiser

10 years of excellence

# Salona 35

maximum stiffness and durability of the boat by adding the layers of carbon fibre on carefully analyzed areas of hull inner liner to obtain equilibrium of stainless steel structure and inner liner attached to it. We believe that Salona 35 is one of the best value 35ft performance cruisers on the market.

America's Cup designer, Jason Ker has designed and optimized Salona 35 performance keel with lower center of gravity. Jason Ker significantly improved ballast to weigh ratio and hydrodynamics of the keel with the use of the latest computational fluid dynamics (CFD) program.

S35 keel and sail plan was optimised for maximum performance combined with ease of handling. S35 keel is made by most advanced

manufacturing and lamination technology and by use of high tech materials. An optimization of the Salona 35 was carried out focusing on keel, sail plan and flotation with new fin keel of similar design as raced in the World Championships in 2011. The Salona 35 optimisation was computed using Numeca Fine-Marine RANS CFD on the Ker Yacht Design computing cluster.

Filled with daylight coming through hull windows with hatches and numerous smart design details, saloon is the perfect place to relax and enjoy the comfort of our new yacht. Standard interior is 2 cabin version with spacious head and large navigation table, functional galley and folding bunk beds in the saloon (optional).



*functional interior*

S35 NEW

S38

S41

S44

S60 NEW

ibc

**salona**  
performance cruiser

10 years of excellence

# salona 35



## Technical specification

<b>LOA (hull)</b>	10,40 m
<b>LWL</b>	9,35 m
<b>B. max. (deck)</b>	3,36 m
<b>Draft</b>	1,5 / 1,75 / 2,15 m
<b>DSPL empty</b>	5.300 kg
<b>Ballast</b>	1.200-1.500 kg
<b>I</b>	13,03 m
<b>J</b>	3,84 m
<b>P</b>	12,50 m
<b>E</b>	4,38 m
<b>Mainsail full batten</b>	32,00 m <sup>2</sup>
<b>Genoa furling</b>	37,50 m <sup>2</sup>
<b>Fresh water tank</b>	200 l
<b>Black water tank</b>	42 l
<b>Fuel tank</b>	90 l
<b>Engine</b>	15,3 kW (21 HP)
<b>Design Category</b>	A (Ocean)
<b>CE Certification</b>	Germanischer Lloyd
<b>Design</b>	J & J design

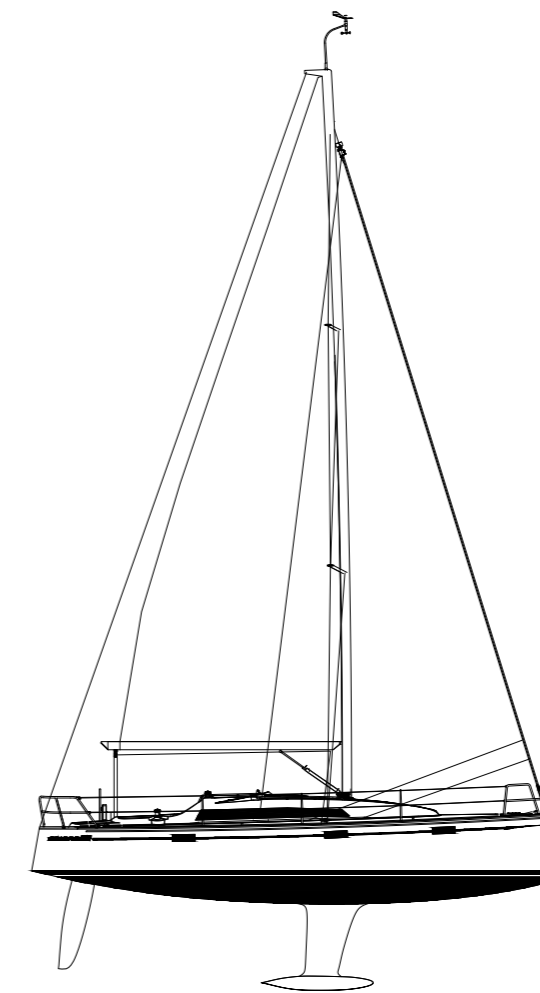

S35 NEW

S38

S41

S44

S60 NEW

ibc

**salona**  
performance cruiser

10 years of excellence

# Salona 38

## The smart **ONE**

The new Salona 38 is a result of combined innovation, the use of latest technology and high tech materials, as well as our experience gained throughout creation of all our models, from 34 to 60ft.

Every Salona is a result of teamwork of external and internal designers among which we are proud to mention J&J Salona 38 designers, Jason Ker (keel optimization), many Olympic and professional sailors, interior

designers, suppliers and most importantly existing cruising or racing Salona customers.

All these people have one simple goal - to design and build globally competitive fast sailing yachts that can win any regatta but at the same time have uncompromised comfort and safety while cruising.

Apart from all the key features that have to be satisfied for each yacht

*„On the way to Portugal to AC45 World Series I stopped in Split, Croatia for the launch of the new Salona 38 which is a new model for the Salona boats range. Salona produce a performance cruiser range with some beautifully built yachts. The 38 was very nice to steer, very well balanced and comfortable.“*

*Dean Barker*

*the smart one*

S35NEW

S38

S41

S44

S60NEW

IBC

**salona**  
performance cruiser

10 years of excellence



# Salona 38

under the Salona name, the new Salona 38 has extremely hard task – to beat our best-selling model, Salona 37 (EU and US Yacht of the year). As on all our models the big stainless steel frame takes loads from the keel and shrouds and spreads them securely to a wide area of the hull. On the new Salona 38 we have gone step further in achieving maximum stiffness and durability of the boat by adding layers of carbon fibre on

carefully analyzed areas of hull inner liner to obtain equilibrium of stainless steel structure and inner liner attached to it. In order to optimize performance, Jason Ker, America's Cup designer, has designed and optimized special performance keel with lower center of gravity and he has significantly improved ballast to weight ratio and hydrodynamics of the keel with the use of the latest computational



*sailing and living on board*

- S35 NEW
- S38
- S41
- S44
- S60 NEW
- ibc



*10 years of excellence*

# Salona 38

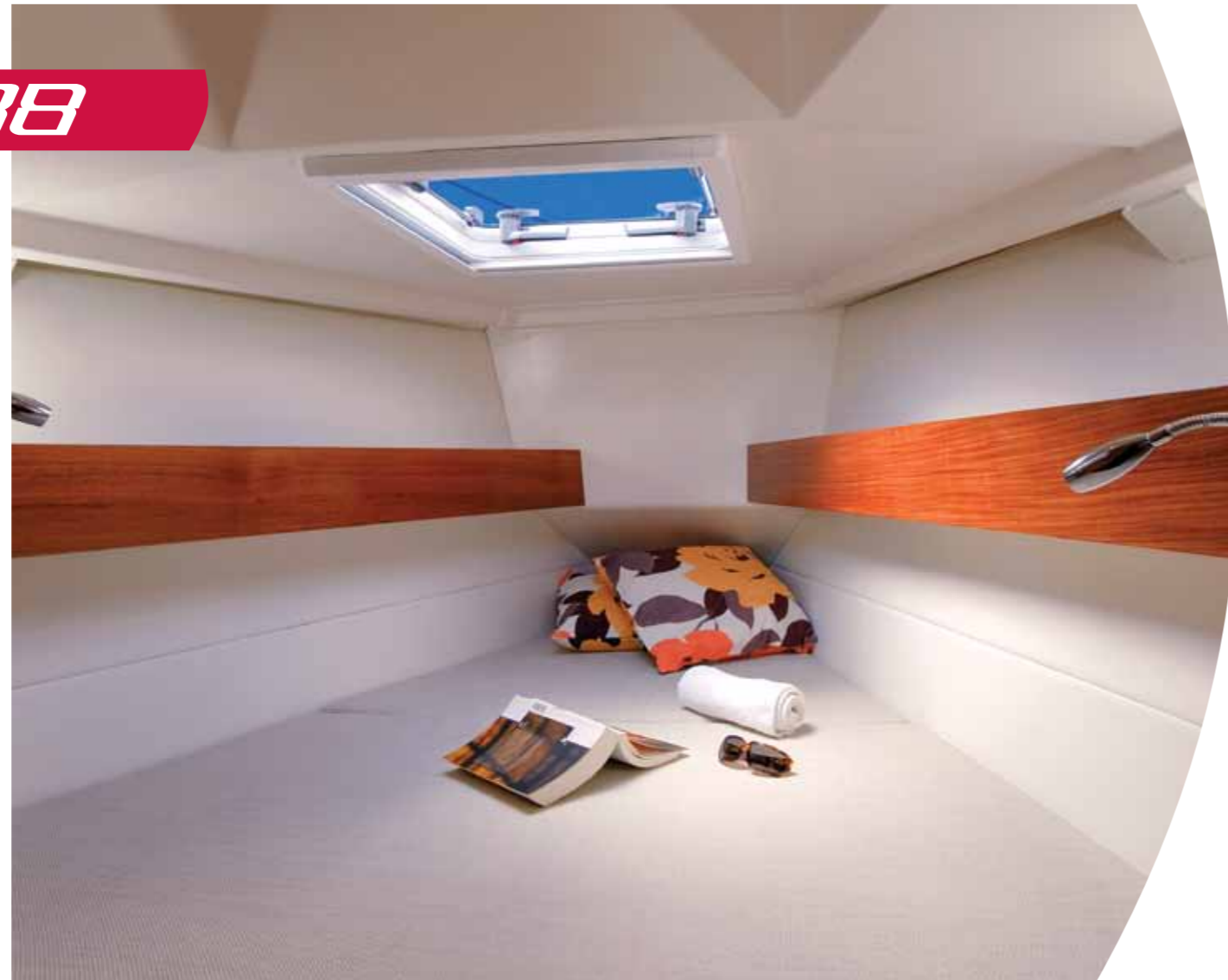

fluid dynamics (CFD) program. Salona 38 prototype was tested by Dean Barker, Emirates Team New Zealand America's Cup skipper. Salona 38 has a comfortable interior that can be associated with those in bigger boats. There is 2 cabin or 3 cabin version with spacious heads and large

navigation table, functional galley and folding bunk beds in the saloon. Spacious and filled with daylight coming through hull windows, with hatches and numerous smart design details, saloon is the perfect place to relax and enjoy the comfort of this latest and by now most advanced Salona yacht.

## Technical specification

<b>LOA (hull)</b>	11,50 m
<b>LWL</b>	10,15 m
<b>B. max. (deck)</b>	3,62 m
<b>Draft</b>	1,75 / 1,98 / 2,28 m
<b>Ballast</b>	2.270 kg
<b>DSPL empty</b>	6.500 kg
<b>I</b>	15,05 m
<b>J</b>	3,80 m
<b>P</b>	14,30 m
<b>E</b>	5,50 m
<b>Mainsail full batten</b>	45,5m <sup>2</sup>
<b>Genoa furling</b>	42,9m <sup>2</sup>
<b>Sail area total</b>	88,40 m <sup>2</sup>
<b>GT</b>	6,59
<b>Fresh water tank</b>	180 l
<b>Black water tank</b>	42 l
<b>Fuel tank</b>	100 l
<b>Engine</b>	21.3 kW
<b>Design Category</b>	A (Ocean)
<b>CE Certification</b>	GL
<b>Design</b>	J&J

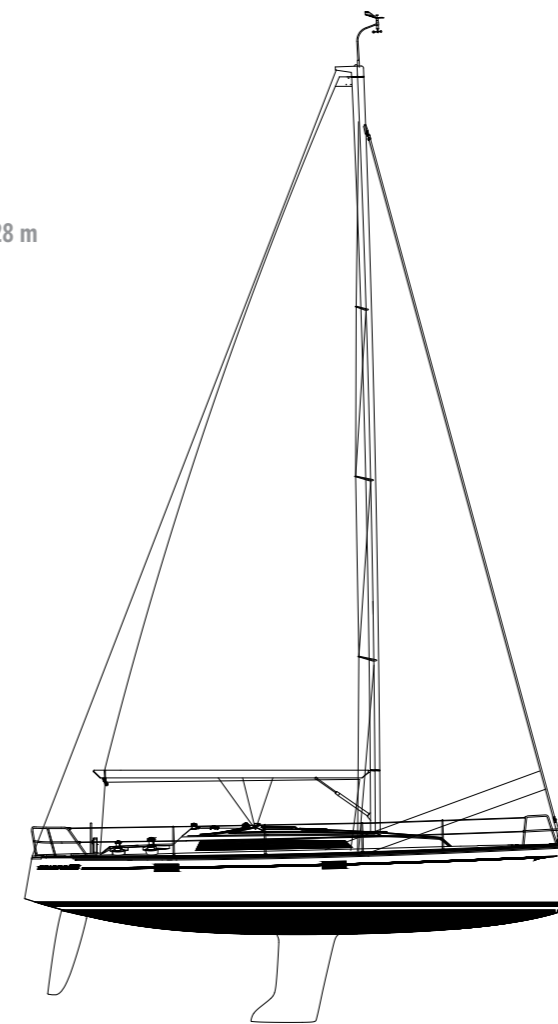

S35NEW  
S38  
S41  
S44  
S60NEW  
ibc

**Salona**  
performance cruiser

10 years of excellence

*Salona 41*

*sailing delight*

## Example of **SUCCESS**



Designed by J&J in collaboration with the in-house Salona development team and with special planning input sought from Maurizio Cossutti (the well-known Italian designer, sailor and race enthusiast), the Salona 41 represents a real team achievement. From a build viewpoint the exciting newly introduced construction techniques are very exciting and the end result offers comfort fused with safety and stunning performance, conforming to all IRC and ORC rules.

Delightfully sleek of line, marrying good looks with an eminently practicable, spacious, clear cockpit and an easily convertible closed to open transom the Salona 41 positively invites you to examine all her features and with its trademark twin steering wheels, narrow lines and low displacement, the under deck Harken furler optimises even the lightest of breezes making full use of the 140% genoa in as little as 5 knots of wind – very much a boating pleasure.

*S35NEW*

*S38*

*S41*

*S44*

*S60NEW*

*ibc*



*10 years of excellence*

## salona 41

Below deck is an ambient mixture of spaciousness, comfortable head room (195cm), tasteful furnishings and hand selected matt finished woods. The standard layout (there are four layouts to choose from) offers a well equipped portside galley, a comfortable saloon area (with convertible table to give an extra 205cm berth) and full size navigation station. There is a very spacious owner's cabin, large stern heads and comfortable double aft cabin.

The comfortable interior arrangement has been built with on board living in mind as typified in the owner's cabin which is equipped with three hatches, each fitted with mosquito nets and dark shade plates, two big under seat lockers with large shelves above and a full size 210 cm berth. There is a self-priming under floor bilge pump with the added ability to switch over to a 3m long pipe for vacuum draining of all bilge and engine compartments.

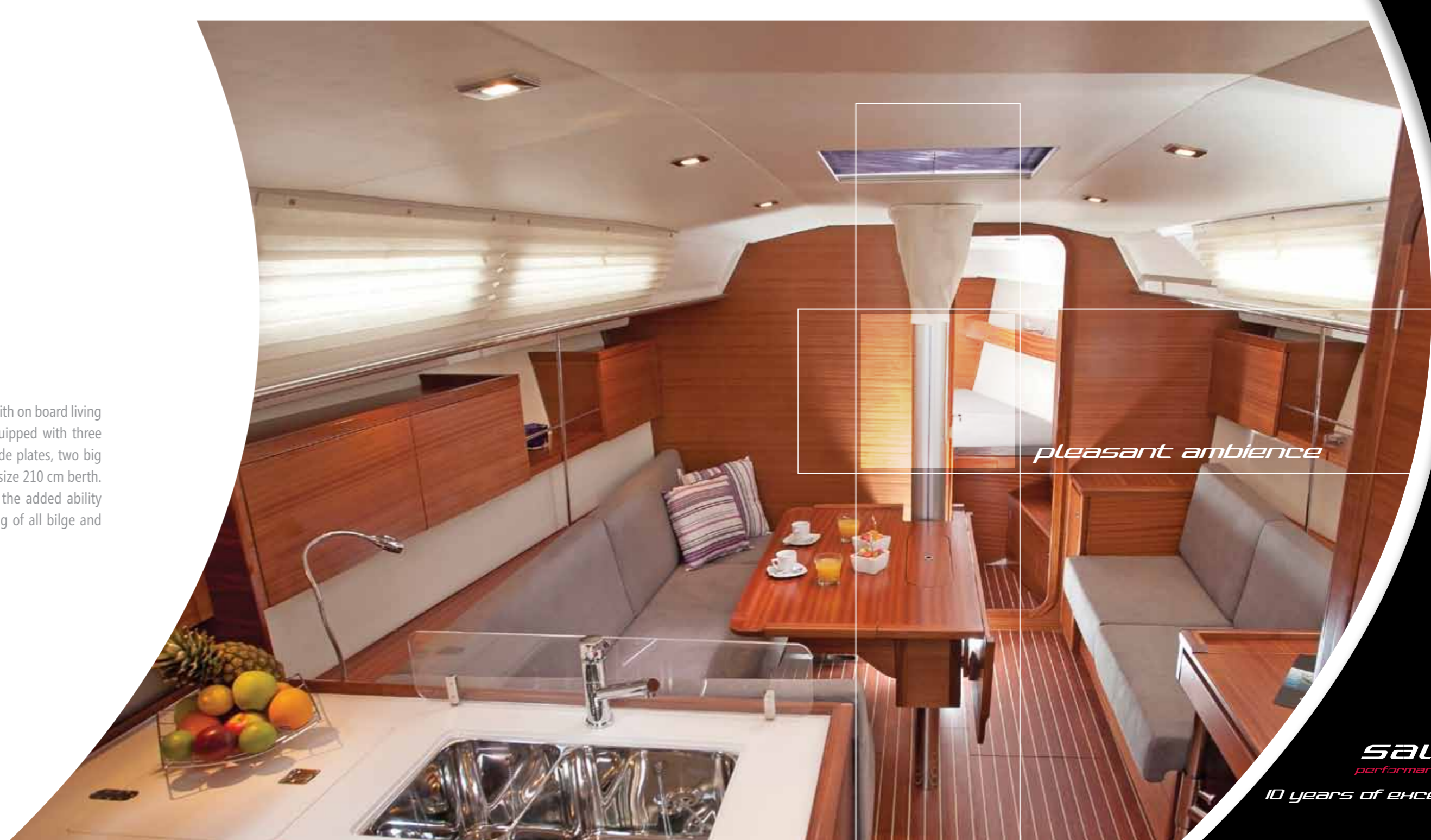

*pleasant ambience*

S35NEW

S38

S41

S44

S60NEW

ibc

**salona**  
performance cruiser

10 years of excellence

# salona 41



## Technical specification

<b>LOA (hull)</b>	12,5 m
<b>LWL</b>	11,45 m
<b>B. max. (deck)</b>	3,84 m
<b>Draft</b>	1,75 / 2,00 / 2,25 / 2,68 m
<b>DSPL empty</b>	7.450 kg
<b>Ballast</b>	2.400 kg
<b>I</b>	15,8 m
<b>J</b>	4,8 m
<b>P</b>	15,6 m
<b>E</b>	5,78 m
<b>Mainsail full batten</b>	53,5 m <sup>2</sup>
<b>Genoa furling</b>	57,6 m <sup>2</sup>
<b>Fresh water tank</b>	220 l
<b>Black water tank</b>	42 l
<b>Fuel tank</b>	220 l
<b>Engine</b>	40 HP
<b>Design Category</b>	A (Ocean)
<b>CE Certification</b>	Germanischer Lloyd
<b>Design</b>	J & J design

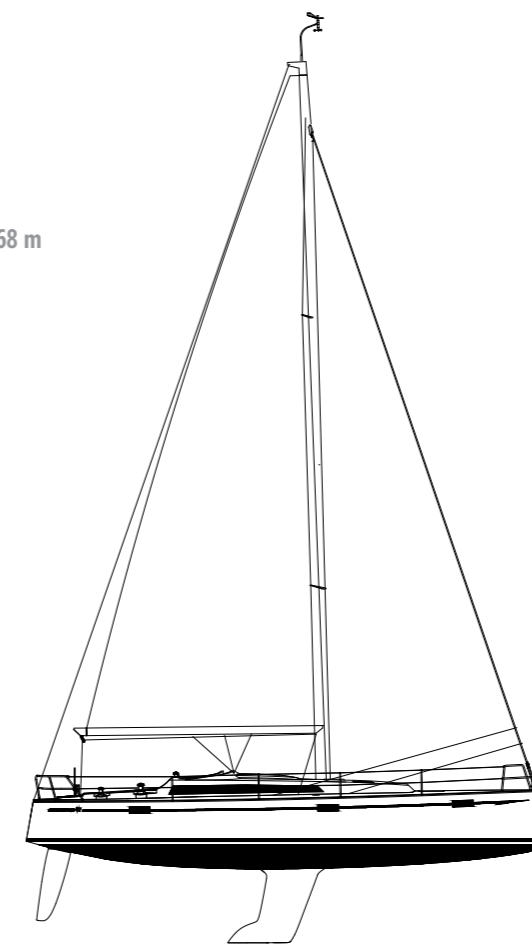

S35NEW

S38

S41

S44

S60NEW

ibc



10 years of excellence

# Salona 44

## Sporty elegance and **INNOVATION**



The Salona 44 takes us to the next level of technology, design, comfort and reliability. She is stunningly impressive to look at and pride of ownership comes naturally. Crew comfort and safety, secured by ergonomically designed layouts offer functional and elegant spaces for pleasant family cruising and makes for easy living. The port side L shaped galley

provides more storage and worktops with strategically placed grab rails to provide a perfect working environment to keep the crew well provisioned even on open waters. The Salona 44 boasts larger everything – from a larger than average fridge, to copious heads, to large and comfortable seating arrangements to enable the entire crew to gather together. Both 3-cabin and 4-cabin versions

*ultimate harmony*



- S35 NEW
- S38
- S41
- S44
- S60 NEW
- ibc



*10 years of excellence*

## Salona 44

are available with king-sized beds and full standing height and, not forgetting good sized wardrobes and storage facilities. The list of options is endless and this is truly a boat built for your special needs.

But this boat is not just about goods looks, however beautiful and elegant they are, the real heart of the Salona 44 is the construction

that lies behind her slender silhouette. Not only is the latest vacuum infusion system used but this is combined with tri-axial orientated woven fiberglass cloth together with other high-tech resins and materials to give the boat a lighter and stronger hull than you are likely to find elsewhere. This is a unique construction method which has a rigid and strong stainless steel frame with its loads spread



*spacious living area*

S35 NEW

S38

S41

S44

S60 NEW

IBC

**salona**  
performance cruiser

10 years of excellence

# salona 44



evenly throughout the hull, giving this craft an unbridled advantage of strength and agility.

And yet, the boat can easily be sailed short-handed with family cruising in mind. The cockpit and deck layouts combine the German mainsheet system, which is led under deck. Special attention has been paid to the development of the twin steering wheel system which, combined

with the allocation of the main traveler, simplifies your sailing. There is also a dedicated life-raft locker located beneath the cockpit and close to the transom, which allows for quick and easy deployment should an emergency arise. The overall feel of the boat is light and airy, the living accommodation is roomy and practical offering comfort, style and whatever kind of sailing you want to enjoy.

S35NEW

S38

S41

S44

S60NEW

ibc

  
**salona**  
performance cruiser

10 years of excellence



# salona 44

## Technical specification

<b>LOA (hull)</b>	13,50 m
<b>LWL</b>	12,16 m
<b>B. max. (deck)</b>	4,19 m
<b>Draft</b>	2,10 / 2,55 m
<b>DSPL empty</b>	9.500 kg
<b>Ballast</b>	3.400 kg
<b>I</b>	16,71 m
<b>J</b>	5,12 m
<b>P</b>	16,68 m
<b>E</b>	6,00 m
<b>Mainsail full batten</b>	57,60 m <sup>2</sup>
<b>Genoa furling</b>	61,10 m <sup>2</sup>
<b>Fresh water tank</b>	400 l
<b>Black water tank</b>	42 l
<b>Fuel tank</b>	270 l
<b>Engine</b>	39,6 kW (54 HP)
<b>Design Category</b>	A (Ocean)
<b>CE Certification</b>	Germanischer Lloyd
<b>Design</b>	J & J design

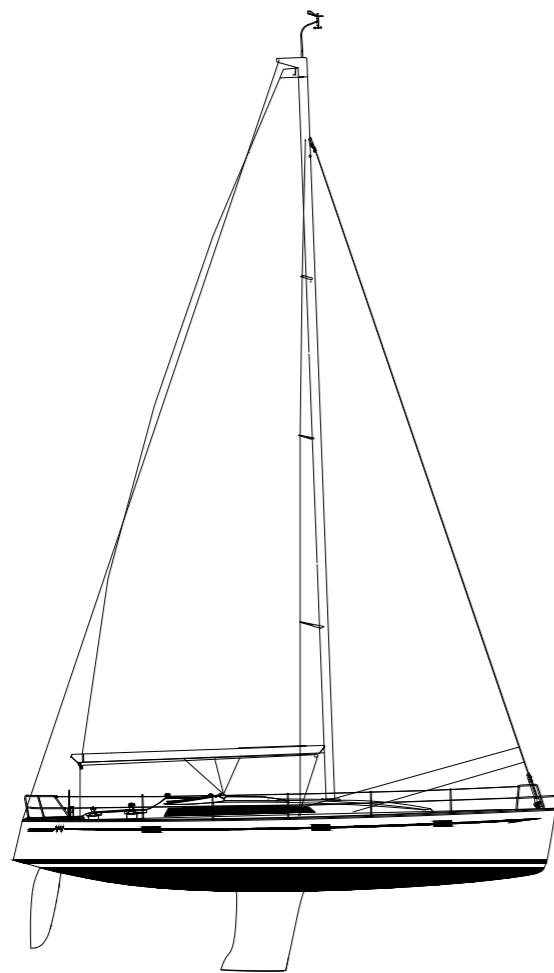

A



B



S35 NEW

S38

S41

S44

S60 NEW

ibc



10 years of excellence

# Salona 60

## The big ONE

Our new sailboat marks the entrance of Salona into a completely new market segment - the market of luxurious semi-custom yachts. The Salona 60 prototype is going to be launched in spring 2013. It is a sailboat with an uncompromised sport design signed by America's Cup designer, Jason Ker. The elegant exterior offers a vast area for outdoor

living while the elegant lines of the hull guarantee good performance for which the Ker's projects are famous all over the world. On the other hand, Salona maintains the spirit of modern, elegant interior that is designed according to the preferences of the owner, and its principal characteristic is a clear communication with the environment.

*\*These are renderings based on current development concepts, which are subject to change without prior notice.*

*the big one*

S35 NEW

S38

S41

S44

S60 NEW

IBC



**salona**  
performance cruiser

10 years of excellence

# Salona 60

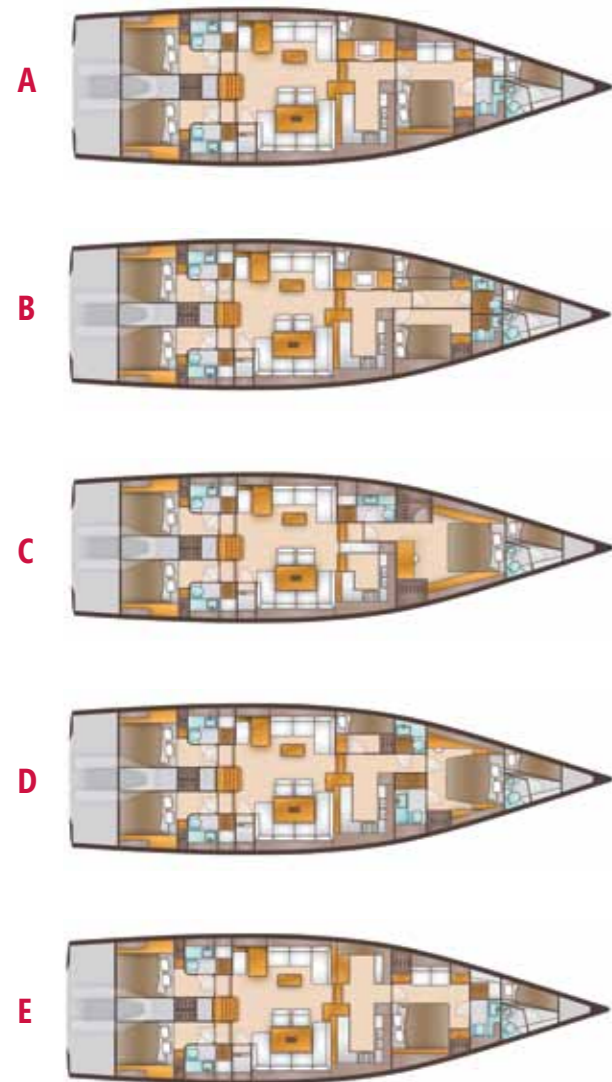

Lateral openings of the sailboat do not serve the decorative purpose only, visual contact with the surrounding and great amount of the natural light create a completely new, relaxing atmosphere in the whole space below deck.

In combination of natural materials and modern textures in the interior, the most advanced technological solutions in the construction of vessels and elegant layout that characterises our sailboats, Salona definitely introduces a new breeze of freshness into the market.



*sophisticated and elegant*

S35 NEW

S38

S41

S44

S60 NEW

IBC



10 years of excellence

# Salona 60

*dream yacht*

## Technical specification

<b>LOA (hull)</b>	19,2 m
<b>B. max. (deck)</b>	5,4 m
<b>Draft</b>	2 / 2,5 / 3 / 3,5 m 2,50 ~ 3,50 m (lifting keel)
These drafts can be varied with custom keels dependent on individual requirements - total lifting range 1 m	
<b>DSPL empty</b>	24 t
<b>Ballast</b>	7 t
<b>I</b>	26 m
<b>J</b>	7,1 m
<b>P</b>	27m, in carbon, 26m alloy
<b>E</b>	8,5 m <sup>2</sup>
<b>Fuel tank</b>	900 l
<b>Water tank</b>	1200 l
<b>Engine</b>	Yanmar 110 HP
<b>Mainsail full batten</b>	139m <sup>2</sup> carbon, 133m <sup>2</sup> alloy
<b>95% Self Tacking Headsail</b>	90 m <sup>2</sup>
<b>104% Overlap Headsail</b>	101 m <sup>2</sup>
<b>Cruising Gennaker</b>	320m <sup>2</sup> carbon, 295m <sup>2</sup> alloy
<b>Design</b>	Ker design

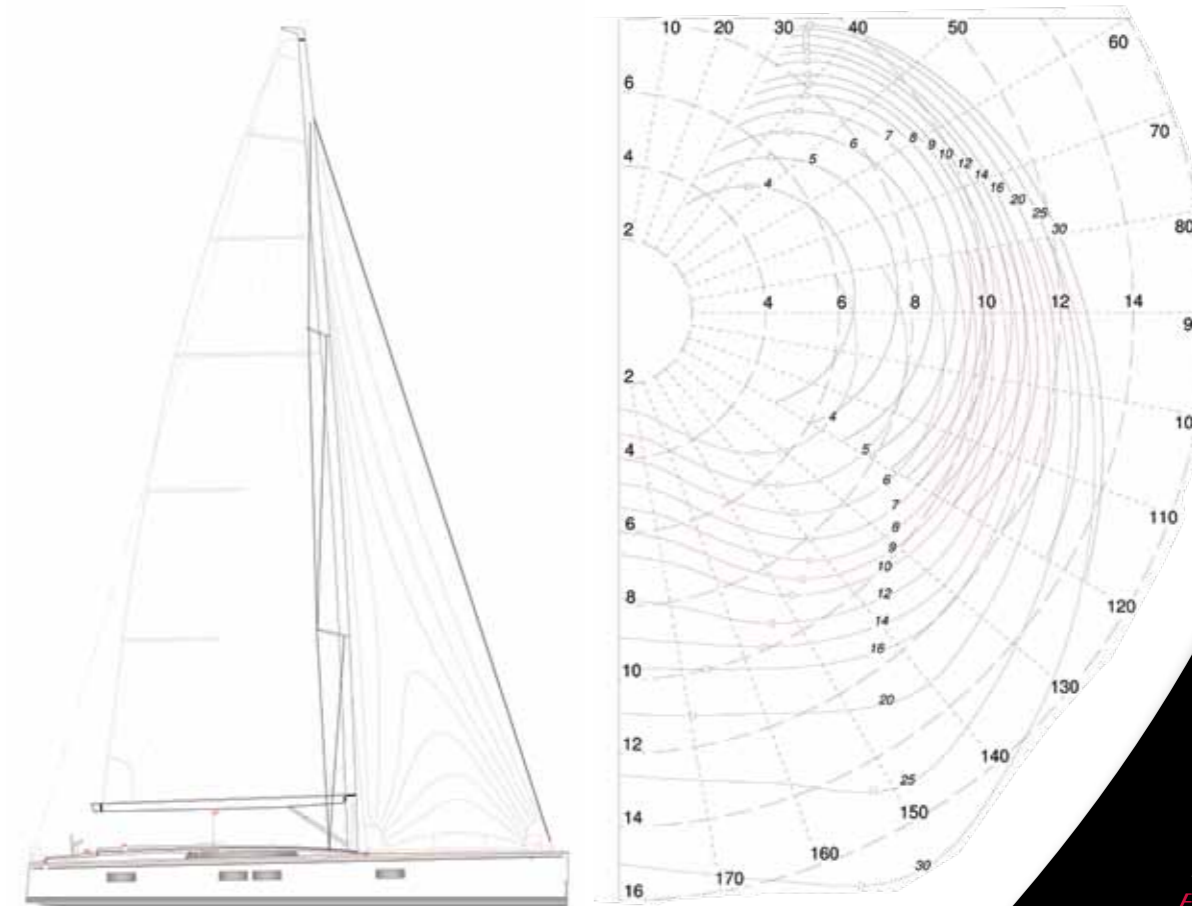

S35NEW

S38

S41

S44

S60NEW

ibc



10 years of excellence

# salona moments

S35NEW

S38

S41

S44

S60NEW

ibc

magic moments

salona44



10 years of excellence

*salona ibc*



*born to win*



*S35NEW*

*S38*

*S41*

*S44*

*S60NEW*

*ibc*

For some sailors, however, there is quite simply the need for speed and the need to win. Our Salona boats are ready for such challenges! Optimizing boats for IRC or ORC handicap formulas has been an exciting innovation which we are proud to offer you - welcome to the IBC range.

**I for INFUSION**

We use vacuum infusion (blending different glass structures and resin quality) to give the just the right combination of lightness and strength to enhance the performance of the boat.

**B for BASALT**

This super light and very strong bulkhead material is used to save weight and give increased torsional rigidity to the internal structure of the boat. The lighter the boat, the faster it goes and with basalt combined with light colour wood we have the added bonus of a great looking interior!

**C for CARBON**

We use carbon fibres for rudder foils, mast, booms and spinnaker poles to ensure lightness and strength. This special combination is a winning formula – just look at our race results.



*10 years of excellence*

*salona ibc*



## Victories

**2012**

**ORC World Championship, Finland**

Salona 37 2<sup>nd</sup>

**North Sea Regatta, Netherlands**

Salona 37

**ÅF Gotland round, Sweden**

Salona 37

**Helsinki Tallinn race, Finland**

Salona 34

**Audi Winter Series Cup, Australia**

Salona 44

**151 Miglia Regatta, Italy**

Salona 41bc

**Trofeo Marina Yachting Regatta, Italy**

Salona 41bc

**ORC2 Alassio Sailing Week, Italy**

Salona 41

**All Girl Crew Regatta, Sydney**

Salona 44

**Frostbike Series, Australia**

Salona 44

**2011**

**Easter Regatta, Croatia**

Salona 42

**Baltic offshore week, Finland**

Salona 37

**ORC European Championship, Norway**

Salona 37

**Airlie Beach Race Week, Australia**

Salona 44

**Flevo race, Netherlands**

Salona 37

**ORC Dutch Championship**

Salona 37

**Henri Lloyd Race, Finland**

Salona 37

**2009/2010**

**MEDITERRANEAN TROPHY OF UNCL, France**

Salona 42bc - IRC 1

**NORTH SEA regatta, Netherlands**

Salona 34 - IRC 2

Salona 37bc - ORC 2

Salona 45 - ORC 1

**ORC DUTCH CHAMPIONSHIP**

Salona 34 - ORC 2

**SPANISH CHAMPION in A2**

Salona 37

**CABBAGE TREE ISLAND RACE, Australia**

Salona 45 - PHS

**Regata 222 Lágrimas de Santa Marta, Spain**

Salona 37

**ORC Croatian Championship**

Salona 42

**Bohus race, Sweden**

Salona 37

**ORC Dutch Championship**

Salona 37

**Other**

**Baltic Offshore Week, Finland**

Salona 37 2<sup>nd</sup>

Salona 37 3<sup>rd</sup>

**Italian Eastern Regatta**

Salona 41bc, 2<sup>nd</sup>

**Easter Regatta, Croatia**

Salona 38, 3<sup>rd</sup>

**Sydney Hobart race**

Salona 44, 3<sup>rd</sup>

**ORCi World Championship 2010, Germany**

Salona 42, 3<sup>rd</sup>

Salona 37, 3<sup>rd</sup>

**Copa del Rey 2011, Spain**

Salona 37, 5<sup>th</sup>

**Magnetic Island Week, Australia**

Salona 44, 3<sup>rd</sup>

*S35 NEW*

*S38*

*S41*

*S44*

*S60 NEW*

*ibc*



**salona**  
performance cruiser

*10 years of excellence*

# salona charter

new  
salona

*experience the pleasure of  
adriatic and salona yachts*



S35 NEW

S38

S41

S44

S60 NEW

ibc

For the forthcoming season Salona Yacht Charter has completely renewed their fleet with new attractive models that will definitely meet your needs.

Salona Yacht Charter offers you a wonderful opportunity to test the yachts in the most beautiful part of the Croatian coast, Dalmatia, and to enjoy our bays, islands, beautiful towns that bear historical importance and numerous hidden places that only you will have the opportunity to reveal...

You can obtain all useful information from our dealer, but we have to warn you that during navigation you might fall in love with our sailboat "at first sight"!

We firmly believe that you will be able to find enough suitable information that will help you choose a boat that will make your holiday extremely enjoyable. From the moment you decide to rent a boat till you return home from cruising, we guarantee that your confidence will be regained in the best possible way and our Salona charter team is at your disposal for all the additional information you may need.

## AB OVO SALONA CLUB Ltd.

Matoševa 8, 21210 Solin

## BASE Marina Kaštela

Obala Kralja Tomislava bb,  
21213 Kaštel Gomilica - Croatia

Tel: +385 21 222 511

Fax: +385 21 222 519

**Base Manager** Darko Škaro

cell: +385 91 22 11 516

**Sales Manager** Kristina Perić

cell: +385 91 22 11 517

booking@salona-sailing.com

www.salona-sailing.com



10 years of excellence





*[www.salonayachts.com](http://www.salonayachts.com)*



*10 years of excellence*

**SALONA YACHTS** Matoševa 8 • 21 210 Solin • Croatia • tel + 385 21 275 022 • fax +385 21 213 020 • [info@adboats.hr](mailto:info@adboats.hr)